

WINstart

Model WS-07U

TWO WAY LCD REMOTE CAR STARTER WITH ALARM

INSTALLATION GUIDE

WIRING DESCRIPTION

6 PIN Primary Starter Harness

RED	12V constant wire (12V positive input) connect to a 12V constant, 30A fuse built-in
RED	12V constant wire (12V positive input) connect to a 12V constant, 30A fuse built-in
YELLOW	12V positive auxiliary output for 2 nd ignition, 2 nd accessory, 2 nd starter (see option # 5), 20A fuse built-in.
BLUE	Accessories wire (12V positive output) connect to accessory wire that controls the heater/air conditioning fan
GREEN	Starter wire (12V positive output) connect to starter wire
ORANGE	Ignition wire (12V positive output) connect to main ignition

4 PIN Harness

BLACK	Ground wire, <i>Important</i> connect to a proper ground
BLUE	IGNITION OUTPUT 1A
GREEN / BLACK	500 mA Negative Parking Light
GREEN	15 A Positive Parking Light

10 PIN Harness

ORANGE	OUTPUT #5: 500mA negative pulse for slide door #1. It can be programmed as window open/close or latching ON/OFF or negative parking light (see option # 22)
YELLOW	OUTPUT #2: 500mA constant negative

WIRING DESCRIPTION

10 PIN Harness

RED / WHITE	Horn or siren wire (500mA negative output) connects to horn or siren. Require a relay if siren is used
YELLOW / BLUE	OUTPUT #1 (500mA negative output) give a pulse to disarm factory alarm
PINK	OUTPUT # 3: 500mA negative output, give a pulse to rearm factory alarm or open Sliding Door #2 or window open/close or latching ON/OFF (see option # 21)
GREEN / BLACK	OUTPUT# 4: 500mA negative output for trunk opener or Transponder by-pass (see option # 8)
WHITE / BLACK	Starter kill disable wire (500mA negative output) connect to starter kill relay
BLUE / RED	OUTPUT #6: 500mA negative 2 nd ignition output or 2 nd slide door (see option #25)
WHITE / GREEN	Unlock wire (500mA negative output) See central door lock connection diagram
WHITE / RED	Lock wire (500mA negative output) See central door lock connection diagram

6 PIN Harness

BLUE	Hand brake wire (negative input) connect to the switched side of hand brake switch (for vehicle with manual transmission only)
BLUE / WHITE	Door trigger negative input, connect to negative door switch
BROWN	Hood wire (negative input) connect to hood pin switch
GREEN / YELLOW	Negative Trunk INPUT

WIRING DESCRIPTION

6 PIN Harness

PURPLE	TACH wire (AC input) connect to TACH signal wire (coil or injector)
WHITE	Brake wire (12V positive input) connect to the switched side of the brake pedal switch

5 PIN Harness Transponder module

RED	Output +12V
BLACK	GROUND
YELLOW	Output #2 : 500 mA negative constant
GREEN	NOT USED
WHITE	Door trigger positive input, connect to positive door switch

WIRING DIAGRAM

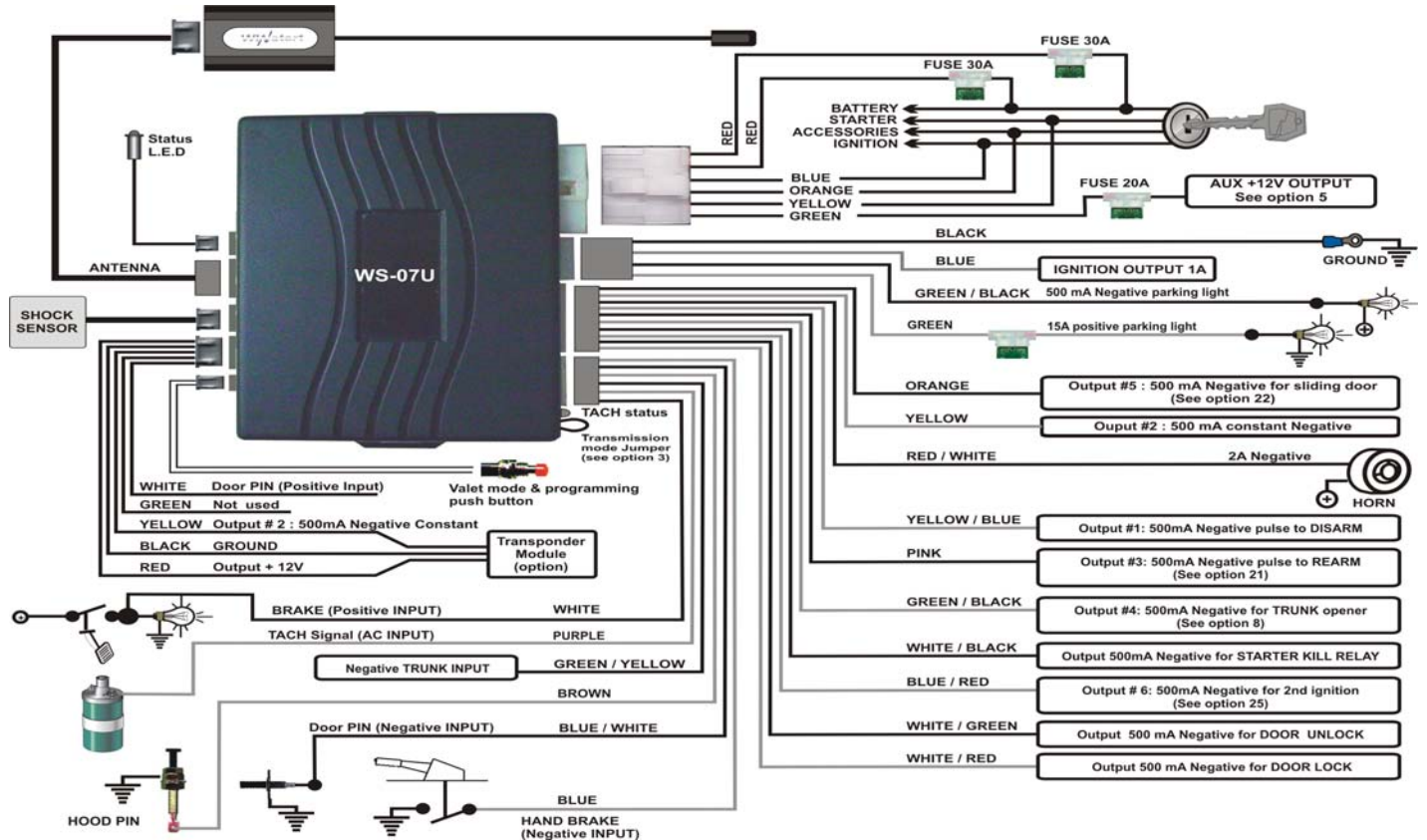

CENTRAL DOOR LOCK CONNECTION

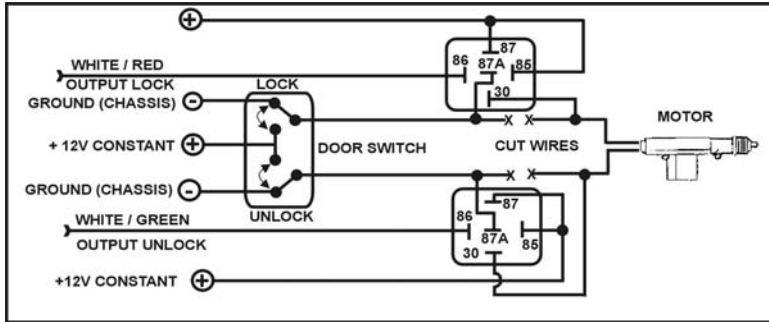

DIAGRAM 1:
REVERSE POLARITY TYPE

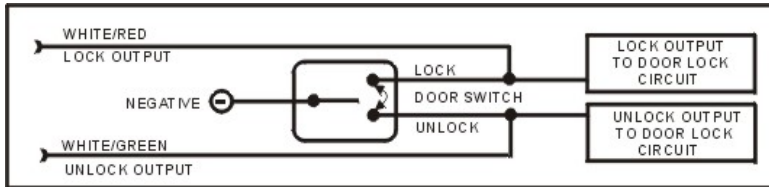

DIAGRAM 2:
NEGATIVE TYPE

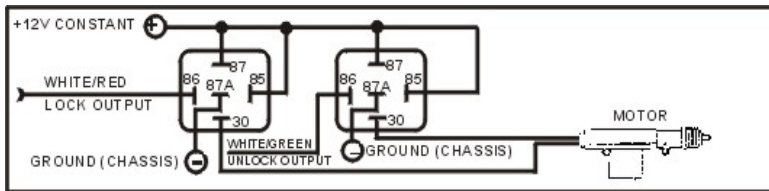

DIAGRAM 3:
ADDING DOOR LOCK ACTUATOR

FIRST STEP INSTALLATION

SELECTING AUTOMATIC OR MANUAL TRANSMISSION:

The system can be used for Manual or automatic transmission.

MANUAL TRANSMISSION:	AUTOMATIC TRANSMISSION
The factory default is set to "Manual". The orange jumper is NOT CUT and programming option # 3 is on "Manual".	CUT the orange jumper before power ON the module, then program option # 3 to "Automatic".

AUTO TACH LEARNING:

After completing the installation, the system must learn the TACH signal before it can start by remote transmitter. Start the engine with the key, the LED on the antenna will flash if a proper Tach signal is detected. After ~30 seconds, the parking lights will flash and the system will beep twice to indicate that the TACH signal was recorded. ***If this operation is not performed, you can not start the vehicle by the remote transmitter.***

Tach learn is performed only one time. This means if you want the Tach signal to relearn, you should program option # 3 for a factory default setting. Most of the time, after the Tach learns the signal, the vehicle will remote start properly. However, some vehicles require adjusting the Tach signal or cranking time. In this case, you can access option #1 to make a Tach fine tuning or option #2 to make a cranking adjustment.

Note: If TACH LED does not flash when Tach learning is performed, it may be necessary to connect to a different Tach source.

VALET MODE:

Turn the ignition key to ON position. Push and hold the receiver button for 5 seconds to enter into valet mode. You have 15 seconds to do this operation. The system will chirp 3 times and the receiver's L.E.D. will stay solid.

To remove valet mode, repeat the same operation. The system will chirp 1 time and the receiver L.E.D. will turn OFF.

PROGRAMMING

Our remote starter is delivered with factory default settings. You can install it without programming or you can modify the configuration to suit your customer's need. **Important: the installation must be completed before accessing programming mode.**

Programming the system:

1. Turn the ignition 3 times OFF to ON and leave the key in the ON position (engine not running).
2. Within 15 seconds, push 1 time on the antenna button. You will hear 5 beeps to confirm that the system is now in programming mode. The L.E.D. built-in receiver will flash slowly.





Note: If the 15 seconds delay has expired, just turn the ignition OFF and repeat steps 1 and 2.

The system has **25 programmable options** and there are 1 to 3 different possibilities to modify. (Except option #21 & #22).

Step 1 Press then release antenna button to select option 1 to 25 (depend on models, see programming chart).

Every time you press on receiver button you will hear one beep. Count the beep to reach desired option.



Step 2 When you have reached the desired option depress brake pedal to confirm.

Step 3 Press button ,  or * on transmitter to choose between different possibilities ( to select column 1, you will hear 1 beep,  to select column 2, you will hear 2 beeps or * to select column 3, you will hear 3 beeps). Depress brake pedal again and count the beep to confirm that the feature has been changed.

Note: if you have more than one option to modify, repeat steps 1 to 3.

Step 4 When finished, Turn ignition OFF to exit programming mode. One long beep will be emitted.

PROGRAMMING CHART

OPT.	FUNCTION	PRESS  BUTTON TO:	PRESS  BUTTON TO:	PRESS * BUTTON TO:
1	TACH fine tuning (See Example#3)	Increase	Decrease	
2	Cranking adjustment	◆ Normal	Slight increase	Increase
3	Factory Default Setting (See Example#4)	Automatic Vehicle	◆ Manual Vehicle	
4	Running time Duration	5 minutes	◆ 15 minutes	30 minutes
5	Power Auxiliary Output	◆ Second Ignition	Second Accessory	Second Starter
6	Glow plug waiting time before starting	◆ 0 second	10 seconds	20 seconds
7	Alarm On/Off	Alarm Off (Starter Only)	◆ Alarm On (Starter With Alarm)	
8	Green/Black output # 4	◆ Trunk opener 1 sec	Trunk opener 5 sec	Transponder by-pass
9	Shock sensor selected as	◆ Pre-warning	Instantly	
10	Door lock Signals	◆ 0.5 second	3 seconds	Unlock double pulses
11	Ignition lock	◆ Disable	Enable	
12	Passive lock	Enable	◆ Disable	
13	Starter kill/Alarm Arming (See Example#1)	◆ Passive arming	Active arming	Active arming without safety rearm
14	Start sequence mode (For manual vehicle only)	You do not need to press on any button of your transmitter to enter the start sequence mode	◆ Press * button of transmitter each time you want to enter into the start sequence mode	

PROGRAMMING CHART

15	Horn/Siren	◆ Horn	Siren	
16	Dome light delay	◆ Disable	Enable	Enable & Doors Bypass for 45 seconds (Automatic) 10 seconds (Manual)
17	Alarm Duration	◆ 30 seconds	60 seconds	120 seconds
18	Door Lock/Unlock configuration	◆ Normal	Unlock before start Lock after start Lock after shut down	Lock only after remote start shut down
19	Arming/Disarming Audible	◆ Disable	Enable	
20	Transmitter code learning (See Example#2)	Press button  until 4 beeps confirmation		
21	Pink: Output #3 Select	1 to 6 choices [◆ 6] see option # 21		
22	Orange: Output #5 Select	1 to 6 choices [◆ 1] see option # 22		
23	Fast Rearm and Lock when close last door (For manual vehicle only)	◆ Disable	Enable	
24	Turbo engine On/Off	◆ Disable turbo	4 minutes turbo running	6 minutes turbo running
25	Blue / Red: Output #6 Select	◆ 2 nd IGNITION	500 ms pulse with disarm	5 sec pulse with disarm

◆ Factory default setting

PROGRAMMING OPTIONS

OPTION 1: TACH FINE TUNING (SEE EXAMPLE # 3)

Occasionally with the AUTO TACH learning feature, you may not reach exact performance on the first try. This option allows you to fine-tune the TACH signal manually.

OPTION 2: CRANKING ADJUSTMENT

If you expect that the vehicle needs adjusting you can force the starter to slightly under crank or over crank. This adjustment may be necessary in some older vehicles or vehicles with diesel engines to help the engine start in extremely cold weather conditions.

OPTION 3: AUTOMATIC OR MANUAL VEHICLE - FACTORY DEFAULT SETTING (SEE EXAMPLE # 4)

By default, the system is delivered for use on a MANUAL transmission. To use the system with an AUTOMATIC transmission, **cut the ORANGE jumper before powering ON** the module then access this option to select AUTOMATIC.

This option also allows you to reinitialize the system back to factory default. You have to perform a TACH learning, otherwise you can not start the vehicle by remote.

OPTION 4: RUNNING TIME DURATION

This option allows you to set the remote start engine running time for 5, 15 or 30 minutes. When remote started, the engine will run for the selected amount of time.

OPTION 5: POWER AUXILIARY OUTPUT

This option allows you to set the AUXILIARY OUTPUT as:

1: 2nd ignition (default)

2: 2nd accessory

3: 2nd starter

OPTION 6: GLOW PLUG WAITING TIME (FOR DIESEL ENGINE)

Diesel engines need to warm up glow plugs before starting. Turn ignition key ON and count how many seconds it takes for the glow plug light to turn OFF then select the closest waiting time.

PROGRAMMING OPTIONS

OPTION 7: ALARM ON /OFF

This option allows you to use the system with Alarm or remote starter only.

OPTION 8: OUTPUT # 4 (Green / Black wire)

Output # 4 can be programmed as trunk opener with 1 sec or 5 second duration, or a transponder by-pass (output release upon accessory turn ON).

OPTION 9: SHOCK SENSOR PRE-WARNING SIGNAL

The shock sensor can be selected with or without pre-warning. With pre-warning, if the vehicle detects a first impact, the car horn will beep 3 times then wait. If the vehicle has been hit a second time within 10 seconds, the system will trigger the alarm.

Without pre-warning, if the vehicle detects an impact, the alarm will trigger instantly.

OPTION 10: DOOR LOCK SIGNAL TIMING

1. Lock or unlock: pulse for 0.75 second
2. Lock or unlock: pulse for 3 seconds
3. Unlock: 2 pulses, the first pulse to open the driver door, the second for all passenger doors

OPTION 11: IGNITION LOCK

This feature allows the system to lock all doors when ignition key is ON. By depressing the brake pedal, all doors will unlock automatically when ignition key is OFF.

OPTION 12: PASSIVE LOCK

Passive lock works only when passive arming option is enable (see option #13). Passive lock allows the system to lock all doors when armed. If this option is disabled, all the doors will lock only when system is armed by transmitter.

PROGRAMMING OPTIONS

OPTION 13: PASSIVE OR ACTIVE ARMING (SEE EXAMPLE # 1)

1. Passive arming arms the starter kill / alarm 30 seconds after the ignition is OFF, hood and all doors are closed.
2. Active arming arms the starter kill / alarm only by remote transmitter. If the system is disarmed accidentally and no doors or hood are opened, the system will rearm itself within 30 seconds.
3. Active arming without safety rearms will arm starter kill / alarm only by remote transmitter. It will never rearm if the system is disarmed by accident.

OPTION 14: FOR MANUAL TRANSMISSION VEHICLE ONLY

You can choose with or without transmitter to program exit sequence. When without transmitter sequence is selected, it does not require pressing * button each time you perform an exit sequence.

OPTION 15: VEHICLE HORN OR SIREN

Horn will give a 500mA negative ground pulse signal when Alarm or Panic is triggered. When Siren option is selected, the system will give a 500mA negative ground constant. We recommend using the relay for siren if installed.

OPTION 16: DOME LIGHT DELAY

If the vehicle comes with a dome light delay, it is important to enable this option. If not, you have to wait until the dome light shuts-off to arm the system. Otherwise the system will beep 5 times every time you arm the system.

Note: When dome light delay mode is selected, the parking lights will flash 3 times when the system is armed.

OPTION 17: ALARM DURATION

This option allows you to choose the alarm duration:

1: 30 seconds 2: 60 seconds 3: 120 seconds

OPTION 18: DOOR LOCK / UNLOCK CONFIGURATION

In some vehicles the doors unlock when the remote starting the car. Use this option to overpass this problem.

PROGRAMMING OPTIONS

OPTION 19: AUDIBLE ARMING / DISARMING



When this option is enabled, the system will chirp each time the system arm or disarm by remote.

OPTION 20: TRANSMITTER CODE LEARNING (SEE EXAMPLE # 2)

This option allows you to add or learn the new transmitter into your system. You can program up to 4 different transmitters.

OPTION 21: OUTPUT # 3 (Pink wire)

This option is used to rearm factory alarm but you can program it to turn ON/OFF any accessories by remote: button [UNLOCK / 2 sec].

Use  to increase and  to decrease to select Output # 3 from 1 to 6 choices as following (default 6):

1 : 500ms with Disarm	2 : 500ms without Disarm	3 : 5sec with Disarm	4 : 5sec without Disarm	5 : Latching On/Off	6 : Re-Arm output
------------------------------	---------------------------------	-----------------------------	--------------------------------	----------------------------	--------------------------

OPTION 22: OUTPUT # 5 (Orange wire)

This option is used to open slide door alarm but you can program it to turn ON/OFF any accessories by remote: button [AUX / 2 sec].

Use  to increase and  to decrease to select Output # 5 from 1 to 6 choices as following (default 1):

1 : 500ms with Disarm	2 : 500ms without Disarm	3 : 5sec with Disarm	4 : 5sec without Disarm	5 : Latching On/Off	6 : Neg parking light
------------------------------	---------------------------------	-----------------------------	--------------------------------	----------------------------	------------------------------

OPTION 23: FAST REARM AND LOCK

When this option is active, the system will lock doors immediately after you close the last door (sequence for manual vehicle only)

OPTION 24: TURBO ENGINE

Some TURBO vehicles require the engine keeps running when ignition key is OFF to slow down the idle. You can select between 4 or 6 minutes running time.

OPTION 25: OUTPUT #6 (Blue / Red wire)

This option can be used as 2nd IGNITION, or to give 500ms pulse or 5 sec pulse for output #6 via double click on button [AUX]



PROGRAMMING EXAMPLES

EXAMPLE 1, OPTION 13: CHANGE FROM PASSIVE ARMING TO ACTIVE ARMING

Option 13, default setting is passive arming. System will arm automatically after ignition key is OFF and the last door is closed. You want to change to active arming.

1. Access programming mode (see programming procedure).
2. Press and release program button 13 times and count 13 beeps.
3. Depress brake pedal to confirm. You should hear 1, 2 or 3 beeps to confirm which option is currently programmed.

Note: If you hear 1 beep, it means current option is passive arming.
If you hear 2 beeps, it means current option is active arming.
If you hear 3 beeps, it means current option is active arming without safety rearm.

4. Press on transmitter to change option:
 - Button  for passive arming, you will hear 1 beep.
 - Button  for active arming, you will hear 2 beeps.
 - Button  for active arming without safety rearm. You will hear 3 beeps.
5. Turn ignition OFF to exit programming mode.

EXAMPLE 2, OPTION 20: TRANSMITTER CODE LEARNING

The transmitter supplied is already programmed to the system. This option allows you to add more transmitters to your system if needed.

1. Access programming mode (see programming procedure).
2. Press and release program button 20 times and count 20 beeps.
3. Depress brake pedal to confirm. Blue L.E.D. built-in receiver will flash rapidly.
4. Press button  on the transmitter 1 time. You will hear 5 beeps. The new transmitter code is learned. If you press on the same transmitter 4 times, all another previously stored transmitter codes in the system will be erased.
5. Turn ignition OFF to exit programming mode.

EXAMPLE 3, OPTION 1: FINE TUNING THE TACH SIGNAL



Even with the AUTO TACH learning features you can not reach the exact setting. *Example: idle is too high.* This option will allow you to fine tune the TACH signal manually, make sure the engine is *not running*.

1. Access programming mode (see programming procedure).
2. Press and release program button 1 time and count 1 beep.
3. Depress brake pedal, you should hear the number of beeps according to Auto-Tach learning. You must count the number of beeps, minimum 1 beep and maximum 10 beeps. If you miss the number of beeps, depress brake pedal again to count the beeps.

Note: In order to increase or decrease TACH signal level, you must carefully count the number of beeps when you depress brake pedal. Decrease when TACH signal is weak and increase when TACH signal is strong.



PROGRAMMING EXAMPLES

Example: you start the engine via the transmitter, if the engine is over cranking decrease the signal level. If the engine releases too fast, increase the signal level.

4. Press button  on the transmitter to increase signal level or press button  to decrease signal level.
5. Depress brake pedal again to confirm the beeps, the number of beeps should be more or less than the number counted in step #3. This confirms that you have changed the setting.
6. Turn ignition OFF to exit programming mode.
7. Start the engine via the transmitter to try the new setting. If you are still not satisfied, repeat step 1 to 6.

EXAMPLE 4, OPTION 3: REINITIALIZE TO FACTORY DEFAULT SETTING

In case of confusion or you want to install the system in another vehicle and you don't want to keep the old settings. The option 3 allows resetting of the system back to factory default setting.

1. Access programming mode (see programming procedure).
2. Press and release program button 3 times and count 3 beeps.
3. Depress brake pedal to confirm.
4. Press button  for Automatic vehicle (1 beep) or  for Manual vehicle (2 beeps) on the transmitter. Factory default setting is reinitialized upon you select 1 beep or 2 beeps.
5. Turn ignition OFF to exit programming mode.

Attention: After resetting to factory default, you have to perform AUTO-TACH learning signal otherwise you can not remotely start the engine.

DIAGNOSTIC FOR REMOTE STARTER:

Each time you try to remote start the vehicle and it doesn't start, the parking lights will flash to indicate the reason why.

1 Flash:	Brake pedal depressed
2 Flashes:	Valet mode ON
3 Flashes:	Hood opened
4 Flashes:	Shut down via transmitter
5 Flashes:	Tach unlearn
6 Flashes:	Running time expired
7 Flashes:	Cranking time expired, engine not running
8 Flashes:	Exit sequence cancelled (manual transmission only)
9 Flashes:	TACH wire disconnected
10 Flashes:	Hand brake not pulled (manual transmission only)
11 Flashes:	Door opened (manual transmission only)
12 Flashes:	Ignition is ON when start via remote

DIAGNOSTIC FOR ALARM:

The remote starter with alarm will keep in memory the last event that triggered the alarm. This will help you find out which defected zones has triggered the system.

First, system must be disarmed by pressing the  button. Open the hood. Depress the brake pedal and count the number of flashes from the parking lights. To repeat the flashes, depress and release brake pedal again.

0 Flash:	No false alarm
1 Flash:	Door has been opened
2 Flashes:	Shock sensor has been triggered
3 Flashes:	Hood has been opened
4 Flashes:	Panic mode has been triggered via transmitter
5 Flashes:	Trunk input has been triggered

LIMITED WARRANTY

The manufacturer guarantees to the purchaser of origin the remote starter and alarm to be free of defect material and labour. However, if it is proven that the product is defective, inside the two year period as from the original date of purchase, the manufacturer will repair or replace, without expenses towards the purchaser, any part (excluding any expenses incurred to deliver the product to the manufacturer) remote starter or alarm which the manufacturer considers defective. After the initial warranty period of 2 years, the manufacturer must repair or replace the defective products with a forwarding costs of 30.00\$US. All the guarantees apply to the original purchaser and ONLY to the vehicle in which it is initially installed. Repairs or replacement of the defective modules must remain at the discretion of the manufacturer. All the other parts, components, accessories or optional equipment relating to the remote starter and alarm are not included in the guarantee of the manufacturer. This guarantee is nontransferable. The original receipt must accompany a request for guarantee of service of any authorized retailer in factory. The fact of not conforming to these conditions can result in cancellation of the guarantee.

This guarantee does not cover the following elements: expenses for labour of removal or reinstallation, transport charges, abuse, misuse or accidental damage of the remote starter and the alarm or parts of the latter. This guarantee is cancelled in the event of amendments, repairs or deteriorations of any part of the product. The manufacturer does not guarantee or does not insure against the loss of the vehicle or its contents. The models of alarm are used only as dissuasion against any possible loss. This alarm can be considered for a reduction of the insurances; premiums please contact your insurance agent for more details. The manufacturer should not be held responsible for any consequent damage connected to a violation of this or any other guarantee express or implicit. This guarantee gives you specific statutory duties. These rights vary according to the area in which you reside.

CERTAIN DAMAGE IS EXCLUDED. The manufacturer declines any responsibility for additional damage caused by the product, including a financial loss, loss of use of the product, hiring of vehicle or all other expenses connected to the maintenance and the guard of the product. The manufacturer declines any responsibility for any additional damage caused by the product or resulting from his use, including the expenses of repair or replacement of other goods damaged or caused by his use, even if the product functions correctly. This product is designed to dissuade from an unauthorized use of the vehicles in which it is installed. The manufacturer does not guarantee that the product is proof against loss and vandalism and the human error or an inadequate use. The manufacturer does not accept any responsibility for any damage occurring any kind that it is caused by a vehicle in which the product is installed or resulting from damage from its use. The manufacturer does not accept any responsibility for any damage resulting from the loss of the vehicle or its contents, caused or claimed caused, directly or indirectly, by a failure of the product.

STARTER WITH MANUAL SHIFT – the installation of a remote starter **MUST** be carried out with an indicated manual transmission remote starter. It is the sole responsibility of the operator of the vehicle to make sure that the vehicle is left with the transmission in neutral when the remote starter is used. The manual transmission remote starter is designed as supplementary measure of safety **ONLY!** The manufacturer does not guarantee or does not insure against any damage or loss of life, which can result from remote starting the remote starter when the vehicle is in gear. The models for manual transmission are only designed to act as a preventive measure against starting in gear; it remains the sole responsibility of the operator or the owner of the vehicle to make sure the transmission is in neutral.